

MARKS	MODIFICATION	QTY.	CHG. BY	DATE
△	Change 7.5 to 7.7	1	G197	30/12/03
△	Change 18.0 to 17.8	1	G197	30/12/03
△	Change 8.0 to 8.1	1	G197	30/12/03
△	Change Terminal type	1	G197	30/12/03
△	Change Base	1	G197	30/12/03

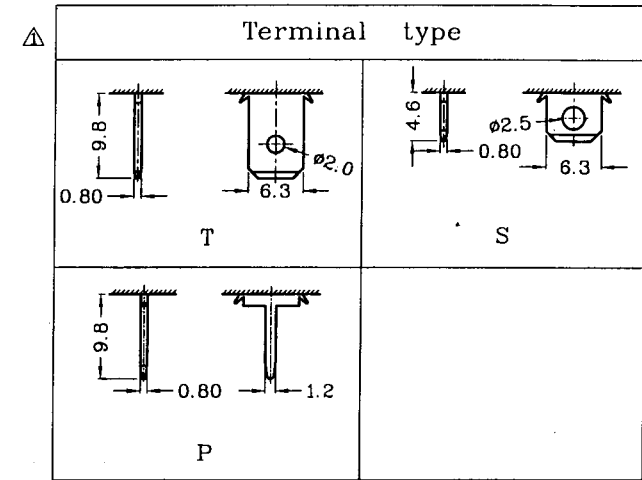

Suggested panel hole size

Panel Thickness	X
0.75~1.25	30.3
1.25~2.0	30.5
2.0~3.0	30.7

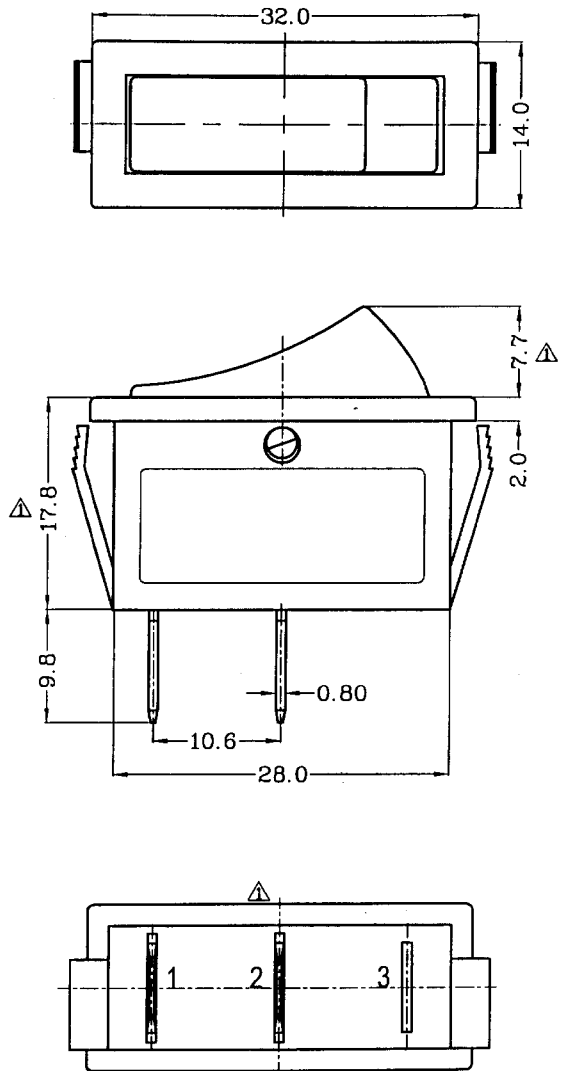
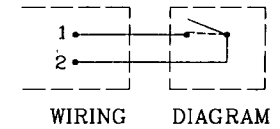
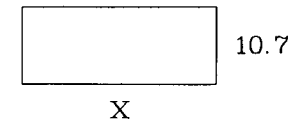

Mm® MERCHANT CORPORATION LTD.				
SCALE: NOT SCALE	TITLE: ROCKER SWITCH	MODEL NO. SR-32D		
DRAWN: [Signature]	DATE: 21-12-03	UNIT: 1.00 mm	FUNCTION: (ON)-OFF	REVISION: A2
CHECKED: [Signature]	DATE: 21-12-03	TOLERANCE UNLESS STATED	PART NO.	DRAWING NO. DR-01002-F004
APPROVED: [Signature]	DATE:	.X: ±0.30 .XX: ±0.15 ANGULAR: +/-2.0°	FINISH: NO BUDS	SHEET 1 OF 1